

## INTERFERENCE OF SOUND WAVES

---

The objectives of this experiment are:

- To measure the wavelength, frequency, and propagation speed of ultrasonic sound waves.
- To observe interference phenomena with ultrasonic sound waves.

**APPARATUS:** Oscilloscope, function generator, ultrasonic transducers, meter stick, angle board.



### INTRODUCTION

In this experiment we deal with sound waves, produced by and detected with ultrasonic transducers. We study the interference of coherent (same phase) waves. The oscillations are displayed on an oscilloscope.

Sinusoidal waves can be characterized by the following parameters:

Wavelength: ..... $\lambda$

Frequency: ..... $f$

Period: ..... $T = 1/f$   
 Wave propagation speed: ..... $c = f\lambda = \lambda/T$ .

The speed of sound through air (at 20 C) is approximately 344 m/s.

### Ultrasonic transducer

A transducer is a device that transforms one form of energy into another, for example, a microphone (sound to electric) or loudspeaker (electric to sound). In this experiment the transducer is a "piezoelectric" crystal of barium titanate which converts electrical oscillations into mechanical vibrations that make sound. The oscillating frequency is near 40 kHz which is beyond what can be heard by the human ear (about 20 kHz).

### Interference of Waves

Below in Figure 1 is a drawing of the basic concept for interference of coherent waves from two point sources. Coherent means that the waves, even though they are from separate sources, have the same frequency and are in lock-step, namely in phase, as they are being emitted. The waves will get out of relative phase because they have to travel different path lengths to reach the same point in space. There, the waves can add constructively if they are in phase, or add destructively if they arrive out of phase. Look at the diagram.

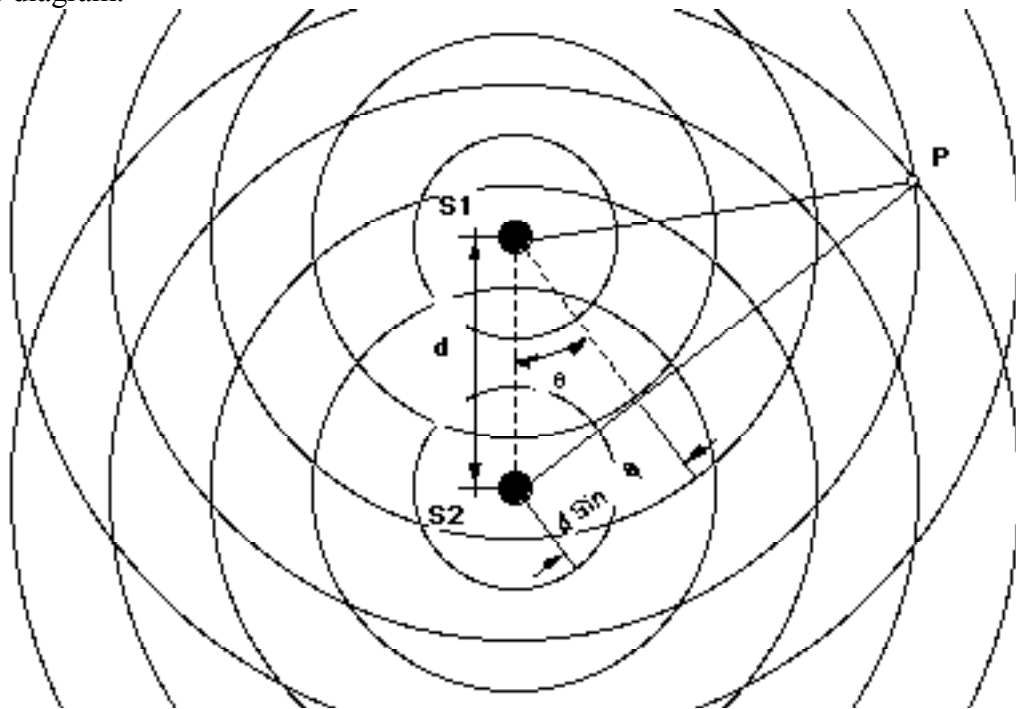

FIGURE 1

S1 and S2 are sound wave sources oscillating in phase because they are driven by the same voltage signal generator; they are separated by distance  $d$ . The sources also emit waves of the same frequency. P is the place where we place a detector, fairly far (in terms

of  $d$ ) from  $S_1$  and  $S_2$ . At point P the path difference to  $S_1$  and to  $S_2$ , is the distance  $d \sin \theta$ . When the path difference,  $d \sin \theta$ , is an integral multiple of the wavelength  $\lambda$ , waves arriving at P from  $S_1$  and  $S_2$  will be in phase and will interfere constructively.

Note that constructive interference gives maximum intensity:

$$d \sin \theta_{\max} = n\lambda$$

where  $n = 0, 1, 2, \dots$  is referred to as the order of the particular maximum.

## The Oscilloscope

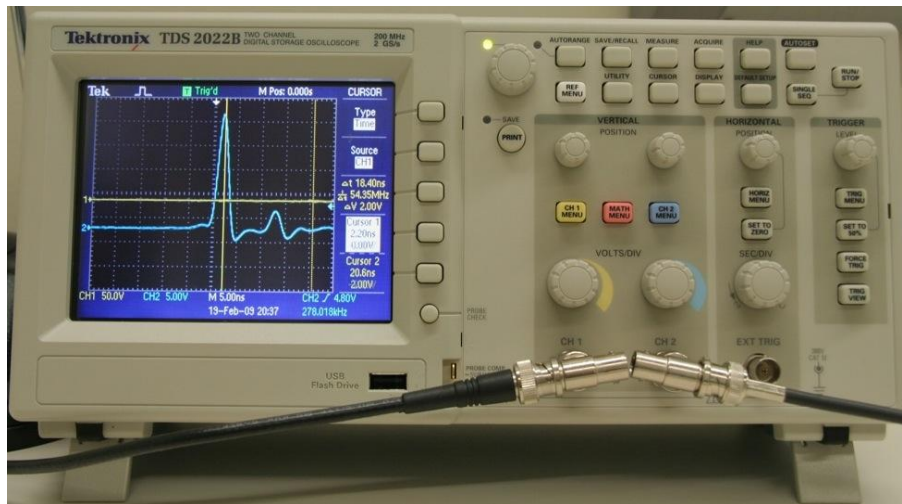

We have used FFTscope, a virtual oscilloscope, in previous labs. If you're unfamiliar with the basic operation of a real oscilloscope the following should be helpful. Essentially, the amplitude of a quantity (usually Voltage) is plotted on the screen as a function of time, in real-time. It is possible to display one or two channels (quantities) at the same time; in this lab we monitor Driving Voltage from the transmitting transducer (via the function generator) and Induced Voltage in the receiving transducers. Here we will monitor the receiving transducer on Channel 1 (CH 1, yellow trace) and the transmitting transducers on Channel 2 (CH 2, blue trace).

## PROCEDURE:

### 1. Learn to use the oscilloscope

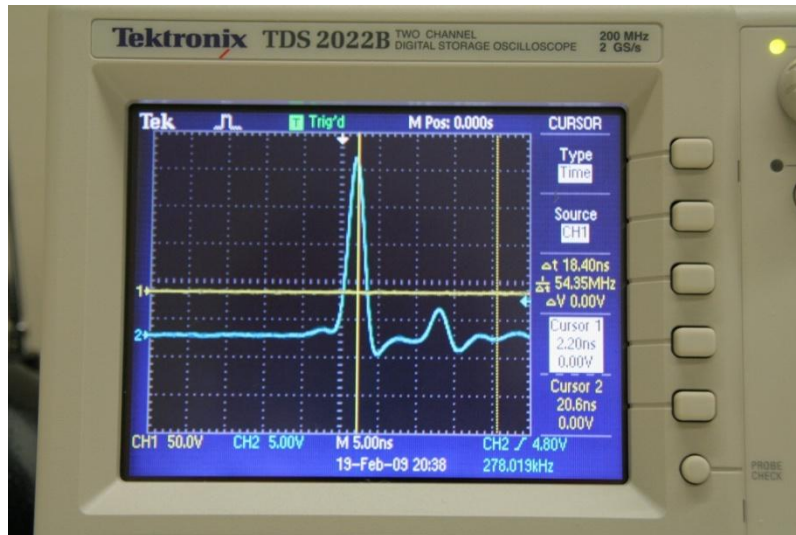

1. Position the oscilloscope in front of you. If you wish you can gently flip out the front legs so that it is tilted upward for easier viewing. Make sure no cables are plugged into the front of the scope for now (T-connectors are okay though). Press the ON button on the top left of the scope and wait 35-40 seconds for the grid to show on the display (ignore the Language selection screen). If the scope is already on, press the DEFAULT SETUP button on the upper-right.

2. You should see two baseline “noise” traces – Yellow for CH1 and Blue for CH2; this is merely background noise since nothing is yet plugged into the scope.

a. Experiment with adjusting the vertical position of both traces by adjusting the Vertical Position knobs above the CH1 Menu and CH2 Menu buttons – this will allow you to arrange your plots so that they are not on top of one another. There is also a Horizontal Position knob above the SEC/DIV knob. This allows one to move the traces left or right.

b. Now fiddle with the Sec/Div knob – this sets the size of your time window (horizontal axis). If you set the value (look at the “M” value at the bottom-center of the screen) to something like 500ms, it'll look like one of those patient monitoring displays at the hospital. The M value is the time interval per square. **Note that this scope will let you examine a time window on the order of a few nanoseconds – an extremely short interval of time.**

c. Restore the Sec/Div knob to some intermediate value and now adjust the Volts/Div on each channel – this adjusts the gain, or sensitivity of the trace on the vertical axis (i.e. potential difference per square). At the highest setting the traces will fluctuate wildly (but randomly); at the lowest setting they'll be relatively calm.

## 2. Measuring frequency

The setup is shown in Fig. 2 (note that Chnl B in the figure is Ch 2 on the oscilloscope, and Chnl A is Ch 1): a variable frequency signal generator drives one ultrasonic transducer; its output is also applied to channel 2 (blue trace) of the oscilloscope. (Later in the experiment two transmitting transducers will be connected to channel 2.) The output of a second receiving ultrasonic generator is applied to channel 1 (yellow trace) of the scope. Channel 2 trace (pattern of the oscilloscope) shows the sinusoidal voltage applied to the transmitting generator; channel 1 trace shows the sinusoidal voltage coming out of the receiving ultrasonic crystal.

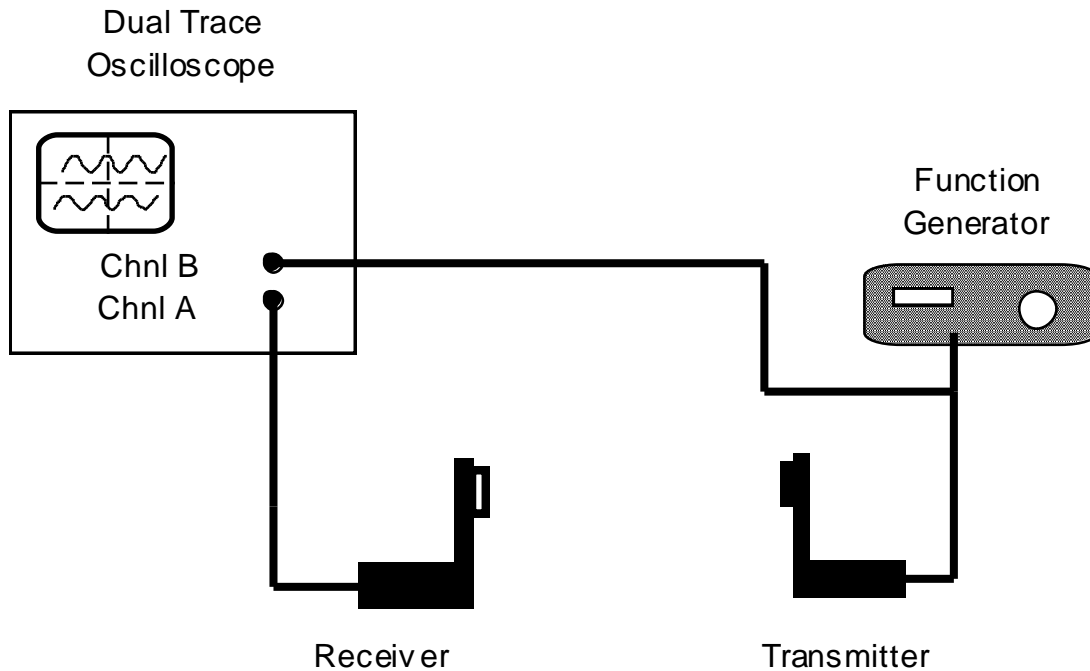

FIGURE 2

Plug the cables into the appropriate channels as pictured in Figure 2 above. Make sure that initially only one of the transmitting transducers is connected to the T-connector. Turn on the function generator by pressing the green power button.

Adjust the scope controls: vertical amplification (Volts/Div), horizontal sweep rate (Sec/Div), vertical position, and horizontal position so that trace 1 shows several, steady sine curves. Place the transmitting transducer facing the receiver at a distance of a few centimeters. If you think the transducers are not functioning (nothing on trace 1), it is most likely that the function generator is not at the exact resonance frequency. You should tune to resonance when the signal getting through to the receiving transducer (trace 1) reaches a maximum. Do this by varying the frequency around 38 to 42 kHz. Be aware that a small red light on the display of the function generator will light up “kHz” if the reading is in kHz (as opposed to Hz). This is, of course, what you want. You can see that sound signal is being received by placing your hand in front of the transducers. By blocking the sound wave, you will disturb or eliminate the yellow trace from Ch 1.

**Warning: Do not exchange your transducers with those from other tables; your three transducers are a matched set.**

Measure the period of oscillation directly from the oscilloscope's screen, taking into account the sweep rate ("M" value at bottom-center of screen). To make the period measurement as accurate as possible, measure the time interval corresponding to several complete oscillations. That is, measure the total time interval and divide by the total number of waves. Use the fine rulings of the square boxes to obtain a precise value. The reciprocal of  $T$  is  $f$ . Compare the frequency  $f_0$  determined with the oscilloscope with both the frequency  $f_{sg}$  of the signal generator and the frequency provide by the oscilloscope in blue in the lower right corner of the screen. The latter two values will likely be more accurate than your computed value, but the point is to gain an understanding of the information conveyed by the oscilloscope traces.

A more precise way to measure the period, which exploits special features of the oscilloscope is as follows. Press the Cursor button near the middle of the dozen buttons at the top of the face of the scope – this will now change the on-screen Menu on the right of the scope screen. The Menu selections can be made by pressing on the buttons immediately to the right of the screen; press the button to the right of Type (twice) so that the Time cursors are activated. Beneath Type the word "TIME" will appear in a white box, and you should now see two vertical lines on the screen. If beneath Source you see "Ch 1" or "Ch 2" the vertical lines will be yellow or blue respectively. Either will do since both traces pertain to waves of the same frequency and period. However, if you see neither "Ch 1" nor "Ch 2" you will need to press the button to the right of Source until you are in one of these settings. Turn the knobs labeled VERTICAL Position CURSOR 1 and CURSOR 2 (i.e. the knobs which usually move the traces the left and right) to move the vertical lines left and right. Align one with a wave crest (or trough) to the left of the screen and one with a wave crest (or trough) to the right of the screen. Then the read out on the right of the screen in blue or yellow will say DELTA beneath which will read the time interval between the vertical lines. This information can also be extracted from the difference in time values listed for Cursor 2 and Cursor 1 just below DELTA. You need only divide by the number of wave cycles in order to determine the period.

### 3. Measuring wavelength

The transmitting and receiving transducer stands fit over, and can slide along, a meter stick. With both transducers fixed in position, the two sinusoidal traces on the scope are steady. What happens to the scope trace from the receiving transducer when you move the receiving transducer away from the transmitting transducer? The traces are providing information about the relative phases of the transmitted and received sound wave (or the driving voltage and receiver voltage).

Measure the wavelength by slowly shifting the receiving transducer a known distance away from the transmitter while noting on the oscilloscope screen by how many complete cycles of relative phase the wave pattern shifts. Don't choose just one cycle, but as many cycles as can conveniently be measured along the meter stick.

#### 4. Calculating Speed of Sound

Use the measured period of ultrasonic oscillations from Part 2 and the wavelength from Part 3 to compute the speed of sound through air. Then repeat the calculation using the frequency from the signal generator. The oscillation period measured with the scope sweep calibration may not be as accurate as the frequency readings on the signal generator or oscilloscope display. Compare your computed values with the standard value of 344 m/s for dry air at 20 C temperature. Then consider which is more accurate and why.

#### 5. Double Source Interference

The setup is similar to Fig. 2, but another transmitting transducer is added. This is effected by plugging the cable of the second transmitter into the T-connector and centering the pair of transmitters on the board (they are attached by a magnet at their base, which can slide). The pair of transmitters are placed side-by-side and driven in phase by a signal generator; a third receiving transducer is at an angle  $\theta$  which can be varied. See Fig. 3, which duplicates the arrangement shown in Fig. 1.

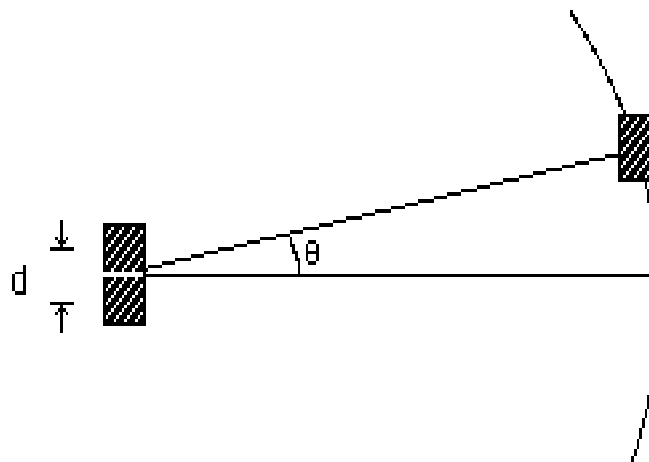

FIGURE 3

We are interested in observing the amplitude of the resultant ultrasonic wave reaching the receiving transducer. When you move the detector you are receiving the combined intensity of the two interfering waves. Sometimes you will see a strong signal while other times little or none. Move the receiving transducer along a circular arc, maintaining a constant distance from the two transmitting transducers. Record the transmitter separation  $d$  and the angular positions  $\theta_{\max}$  for interference maxima. The separation between transmitters should be kept as small as possible, while the distance of the receiver should be as large as possible. However, you may have to compromise on the inter-transmitter distance you choose since fewer maxima will be observable for smaller distances. For this reason, it may not be possible to see the fourth order maximum. Suggestion: rather than plotting  $\theta_{\max}$  readings directly from the protractor, try taking corresponding left-side and right-side values and average them, thus eliminating any error in judging where the center line is.

Confirm the constructive interference relation,  $n\lambda = d \sin \theta_{\max}$ , by plotting  $\sin \theta_{\max}$  as a function of the integer  $n$ . (**Take values for  $n$  and  $\theta_{\max}$  on the right side as positive and those on the left as negative** so your plot is a straight line ( $\sin \theta = -\sin \theta$ ) rather than a "V"). The slope of your best straight line will enable you to calculate  $\lambda/d$ , and then the wavelength  $\lambda$  in terms of the measured distance,  $d$ , between the transmitters. Compare this with the value of  $\lambda$  measured in part 4. Obviously the slope will also give you  $d/\lambda$ . Thus you can find the separation  $d$  in terms of the theoretical wavelength  $\lambda = c/f$ . Compare this with the value of  $d$  directly measured.

## INTERFERENCE OF SOUND WAVES

### LAB REPORT FORM

Name: \_\_\_\_\_ Section: \_\_\_\_\_

Partner: \_\_\_\_\_ Date: \_\_\_\_\_

#### 2) Frequency Measurement

Oscilloscope Time Base Per Div (TB): \_\_\_\_\_

Number of Waves Counted on Screen (NW): \_\_\_\_\_

Number (& fractional parts) of Divisions Covered by Waves (ND): \_\_\_\_\_

Period of One Wave =  $TB * ND / NW =$  \_\_\_\_\_ Frequency = \_\_\_\_\_

Frequency from signal generator,  $f_{sg} =$  \_\_\_\_\_

Frequency from oscilloscope display = \_\_\_\_\_

#### 3) Wavelength Measurement

Number of Waves Moved on Oscilloscope  $N_w =$  \_\_\_\_\_

Initial Position of Movable Sensor  $P_i =$  \_\_\_\_\_

Final Position of Movable Sensor  $P_f =$  \_\_\_\_\_

Distance sensor moved,  $P_i - P_f = D =$  \_\_\_\_\_

Length of One Wave, Wavelength =  $D/N_w =$  \_\_\_\_\_

What happens to the scope trace from the receiving transducer when you move the receiving transducer away from the transmitting transducer? How does this allow you to calculate wavelength? Explain.

#### 4) Speed of Sound: Use your wavelength and frequency (as determined with oscilloscope) to calculate $c$ . Do the same with the function generator frequency.

$c = \lambda f_0 =$  \_\_\_\_\_  $c = \lambda f_{sg} =$  \_\_\_\_\_

Compare your computed values with the standard value of 344 m/s for dry air at 20 C temperature. Which is better?

5) Interference of Sound Separation of Sources, d: \_\_\_\_\_

$\theta_{\max}$	$\sin(\theta_{\max})$	n (maximum #)

Graph  $\sin(\theta_{\max})$  vs. n. Measure slope of line fitted to data.

$$\text{slope} = \lambda/d = \text{_____} \quad (\text{recall, } n\lambda = d \sin \theta_{\max}) \quad \text{use measured d to get } \lambda \text{ _____}$$

Compare wavelength measured on the oscilloscope (Part 3) with the value from interference (Part 5):

$$R \text{ (ratio)} = \lambda_{\text{osc}} / \lambda_{\text{int}} = \text{_____}$$

The slope of your best straight line also enables you to calculate  $(d/\lambda)$ , and thus the separation  $d$  in terms of the theoretical wavelength  $\lambda = c/f$ . Use the theoretical value of  $c$  and the value of frequency which gave the most accurate speed in part 4 to compute  $\lambda$ . Compare this with the value of  $d$  directly measured.