

The Cyclotron Magnet and RF Oscillator

Professor Gershenson
Modern Physics Lab.
Carolyn Chun

I. Capacitor Approximation

If we let the pole faces be flat, or very close to flat, we can approximate the magnetic field by hypothetical “magnetic capacitor.” The magnetic field between the pole faces can be calculated using electric field equations between two charged plates, since it acts in exactly the same fashion.

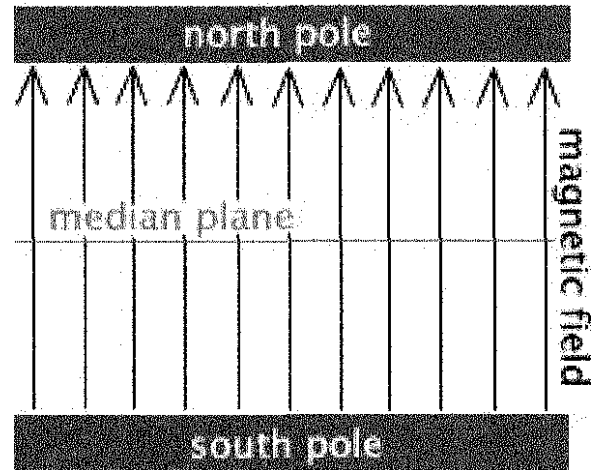

Figure 1: “Magnetic capacitor”

In order to introduce a restoring force, replace the cylindrical pole face with a slice from a sphere. This bends the field lines outward at the middle, so that the force on the moving charged particle is toward the center of curvature and toward the median plane. These field lines adjust delinquent particles, so that the beam stays close to the median plane, which increases the intensity of the usable beam. The capacitor geometry can still be used as a rough approximation of the magnetic field. For a particular change in field strength, the obvious calculations for determining the parameters of ρ , the radius of curvature of the sphere, and θ , the angle of the slice taken from the sphere, of the pole piece are done in the following manner. P is the percent change in the vertical strength of the field, since the vertical strength decreases as the horizontal focusing component increases. Thus, based on a given change in field and a given pole spacing and size restrictions, we can determine the necessary pole face shape.

The “Magnetic Capacitor” calculations are as follows.

$$P = \% \text{ change} = \frac{\Delta|\vec{B}|}{|\vec{B}|} = \frac{1}{D} \frac{1}{D+2h} = \frac{2h}{D+2h} \Rightarrow h = \frac{PD}{2+2P}$$

$$\rho - h = \rho \cos \theta \rightarrow \rho = \frac{h}{1 - \cos \theta}$$

$$R = \rho \sin \theta \quad R = \frac{h \sin \theta}{1 - \cos \theta} \rightarrow \theta = 2 \arctan \left(\frac{h}{R} \right) \quad \rho = \frac{R}{\sin \left[2 \arctan \left(\frac{PD}{2R(1+P)} \right) \right]}$$

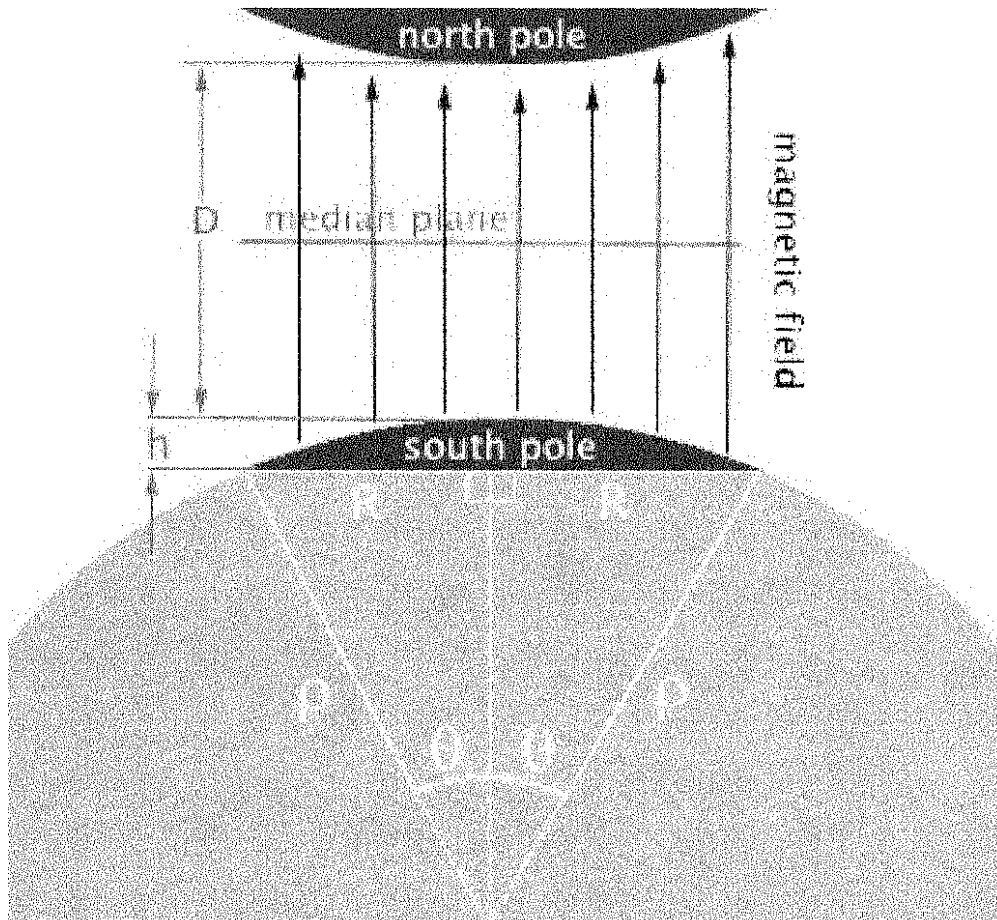

Figure 2: Field geometry for a “magnetic capacitor”

11. Point Source Approximation

A second approximation for the magnetic field at the median plane can be calculated using a monopole model, or a point charge in electric field terminology.

This model is better than the capacitor model in that the field lines are perpendicular to the pole face, as we would expect. However, this model is inferior to the capacitor model since the field lines are not perpendicular to the median plane.

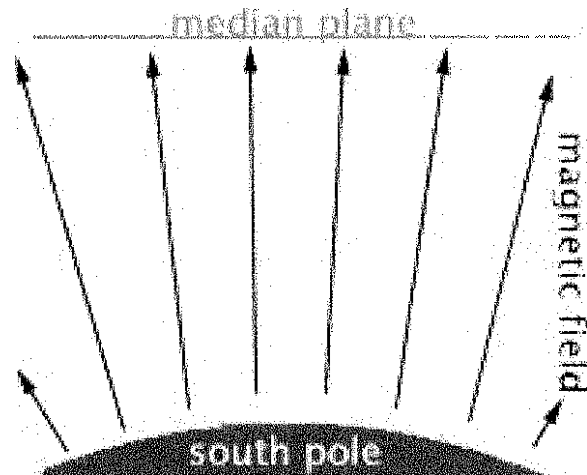

Figure 3: Point source magnet

Using the equations for electric field due to a point charge, we can calculate the measurements for constructing such a pole piece for the necessary change in vertical field strength as follows.

$$\int_0^R E \cdot dr = \frac{q}{\epsilon_0} \rightarrow |\vec{B}| \propto \frac{1}{R}$$

$$P = \%change = \frac{\Delta N}{|\vec{B}|} = \frac{r_2 - r_1}{\frac{1}{r_2}}$$

$$r_1 = H \quad r_2 = \frac{H}{\cos \theta}$$

$$P = 1 - \cos \theta \quad \theta = \cos^{-1}(1-P)$$

$$R = \rho \sin \theta \quad \rho = \frac{R}{\sin[\cos^{-1}(1-P)]}$$

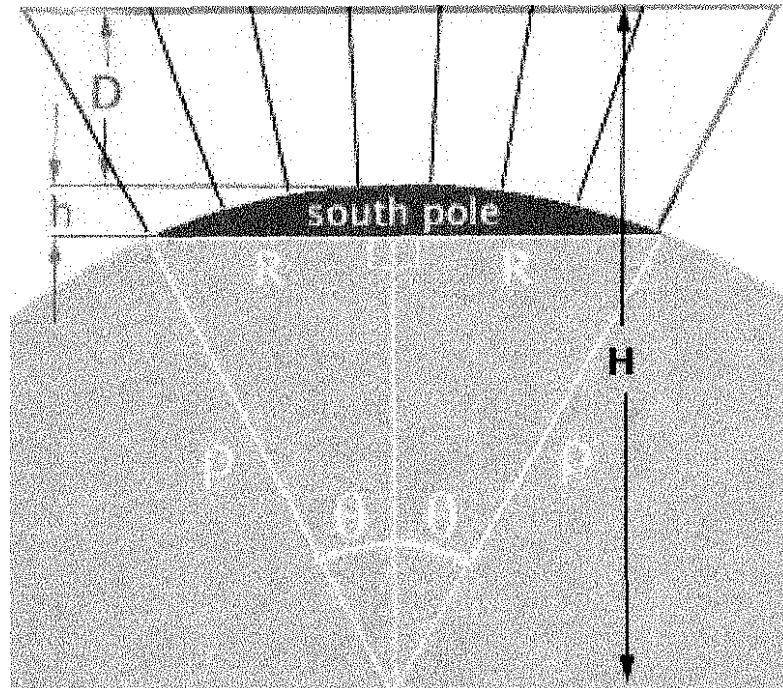

Figure 4: Field geometry for a point source magnet

III. Dipole Approximation

A better approximation for the magnetic field at the median plane can be calculated using a dipole model.

This model is better than the capacitor model because the field lines are perpendicular to the pole face, as we would expect. This model is also better than the point source approximation since the field lines are perpendicular to the median plane.

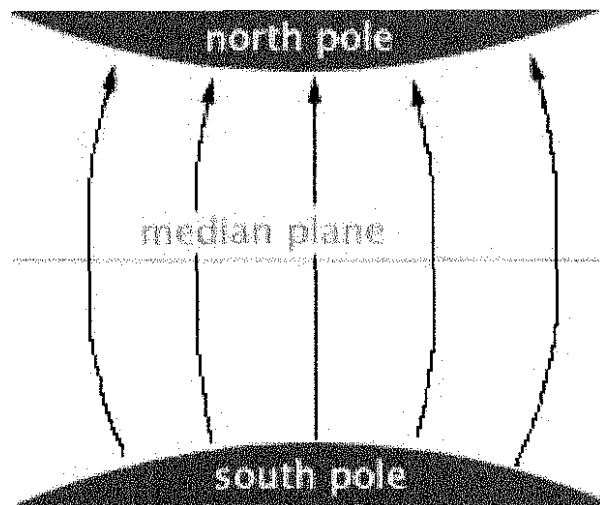
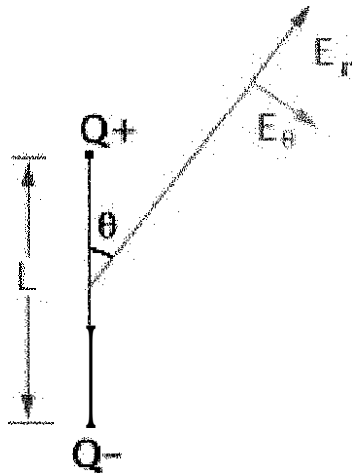

Figure 5: Dipole magnet

Using the equations for electric field due to a dipole, we can calculate the parameters for constructing the pole face based on the desired change in vertical magnetic field strength.

Calculations for a electric dipole are as follows.



$$|\vec{E}_r| = \frac{QL \cos \theta}{2\pi\epsilon_0 r^3} \quad |\vec{E}_\theta| = \frac{QL \sin \theta}{4\pi\epsilon_0 r^3}$$

And, clearly, the field at the origin is as follows.

$$|\vec{E}_{(0)}| = \frac{2Q}{\pi\epsilon_0 L^2}$$

However, under the conditions of the median plane, we make the following observation.

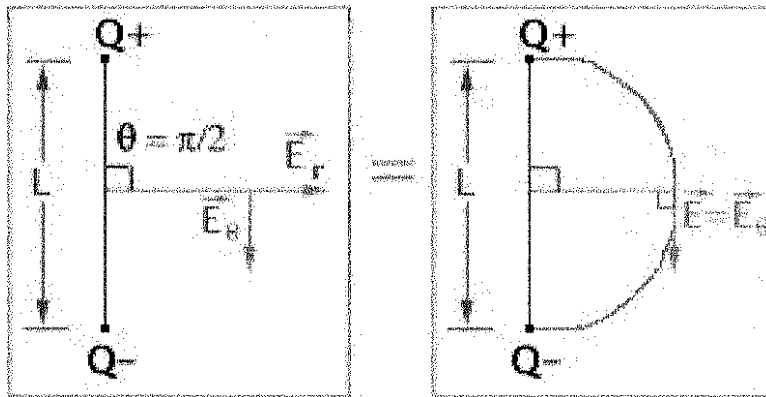

Thus, at a point on the median plane not at the origin, we find the following.

$$|\vec{E}| = |\vec{E}_\theta| = \frac{QL}{4\pi\epsilon_0 r^3} \rightarrow |\vec{E}_{(R)}| = \frac{QL}{4\pi\epsilon_0 R^3}$$

$$P = \frac{\Delta B}{B} = \frac{\Delta E}{E} = 1 - \left(\frac{L}{2R}\right)^3$$

Thus, we can find L given P, which is all the information we need to construct the pole piece.

IV. The Analysis

Each of the three models suggests a different pole piece shape. In order to change the vertical field strength by 3%, the models suggest the following pole shapes.

Approximation	Radius of Curvature (in.)	θ (degrees)
"magnet capacitor"	300	1.14
point source	30.15	11.48
dipole magnet	4.94	33.99

Unfortunately, the best approximation, the dipole, suggests a magnet face that fails due to our space restrictions. The problem is that the pole face has to sit on a cylinder of radius R , which

is 6". Thus, the slice must have a radius, r , of 6" at the bottom. Since there is a fixed gap for the pole piece to fit into, we can simply calculate the smallest radius of curvature

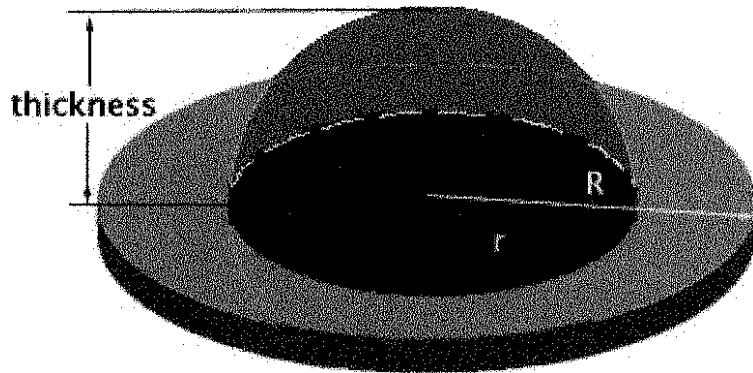

Figure 6: A pole piece with too much height and not enough radius

possible for a pole piece that will have a maximum thickness of 0.84375" and a radius of 6" at the bottom.

Approximation	Radius of Curvature (in.)	θ (degrees)
"best fit"	21.76	16.01

Thus, we have found that, using this slice from a sphere model, the most accurate approximation model calls for a sphere with radius of curvature of 21.76" and a slice of 32.02'.

V. A New Development

The problem with a spherical pole face is that the screw holding the piece must be within 0.25" of the edge. Using the spherical approximation, the thickness of the pole piece at the location of the screws would be about 0.1". Another model to consider would be a pole piece with a flat surface at the edge with a thickness sufficient for the screws and a kind of lump in the middle with a flat top, as shown in this diagram.

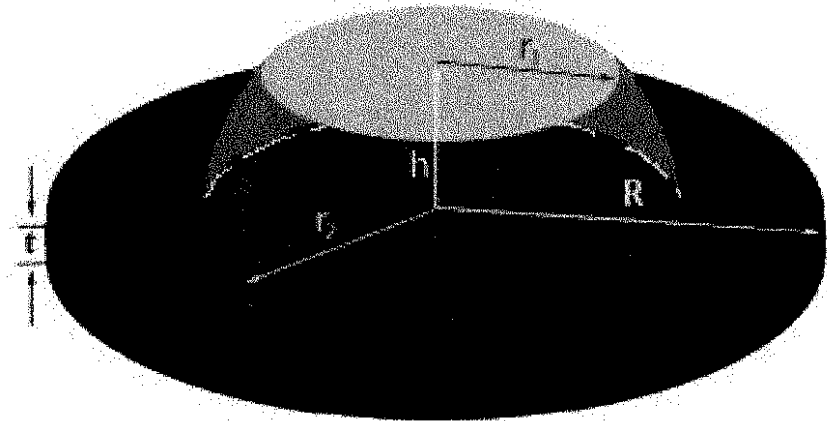

Figure 7: The lump model

This model combines the dimensions of the dipole model with the necessary radius requirements. The following parameters optimize this model for a 3% change in field strength.

R (in.)	r₂ (in.)	R-r₂ (in.)	r₁ (in.)	t (in.)	h (in.)	ρ of lump (in.)	θ of lump (deg.)
6	4.99	1.01	1.98	0.3	0.54	19.64	14.71

VI. Pole Piece Conclusions

In order to manipulate the magnetic field lines between the pole pieces, clearly non-standard pole pieces must be designed. From the refinement of the slice approximation, we have arrived at a “best fit” model. In negotiating with the space and mechanical restraints, we have constructed a “lump model.” The latter seems to be best-suited to the needs of the cyclotron, thus far.

However, a second look at restoring forces suggests that the dipole approximation may not be accurate after all. Restoring forces exist in a magnetic field which decreases

in magnitude with increasing radius. This can be accomplished by requiring the gap length between the magnet pole to increase and flux density to decrease as radius increases. A radially decreasing field can be described as $B_z = B_{z0} (\frac{r_0}{r})^n$ for $n \geq 0$, where $n = 0$ implies a uniform field and $n > 0$ implies a restoring force. The magnitude of this restoring force is proportional to the displacement from the median plane.

$$F_z = evB_r = -ne\omega_0 B_z z = -\kappa_z z \rightarrow F_z \propto -z$$

Restoring forces consequently act on particles displaced vertically from the median plane for values of n between 0 and 1. Both directions of transverse oscillations are damped to smaller amplitudes with increasing magnetic field, varying with $\sqrt{B_z}$.

Calculating the respective n values for the dipole approximation and the point source approximation and the capacitor approximation, we observe the following.

Approximation	n value
capacitor	0
point source	1
dipole	3

Thus, the dipole approximation seems no longer fitting. Clearly, there are flaws in each of the approximations. The construction and testing of the pole pieces in question will either demonstrate the failure of each model, or prove the suitability of at least one of them.

The magnitudes of the magnetic fields in the vertical direction for both the dipole approximation and the point source approximation fit the requirement of decreasing with increasing radius. For example, the strengths of the field in both directions is shown for the point source approximation (see figures 8 and 9).

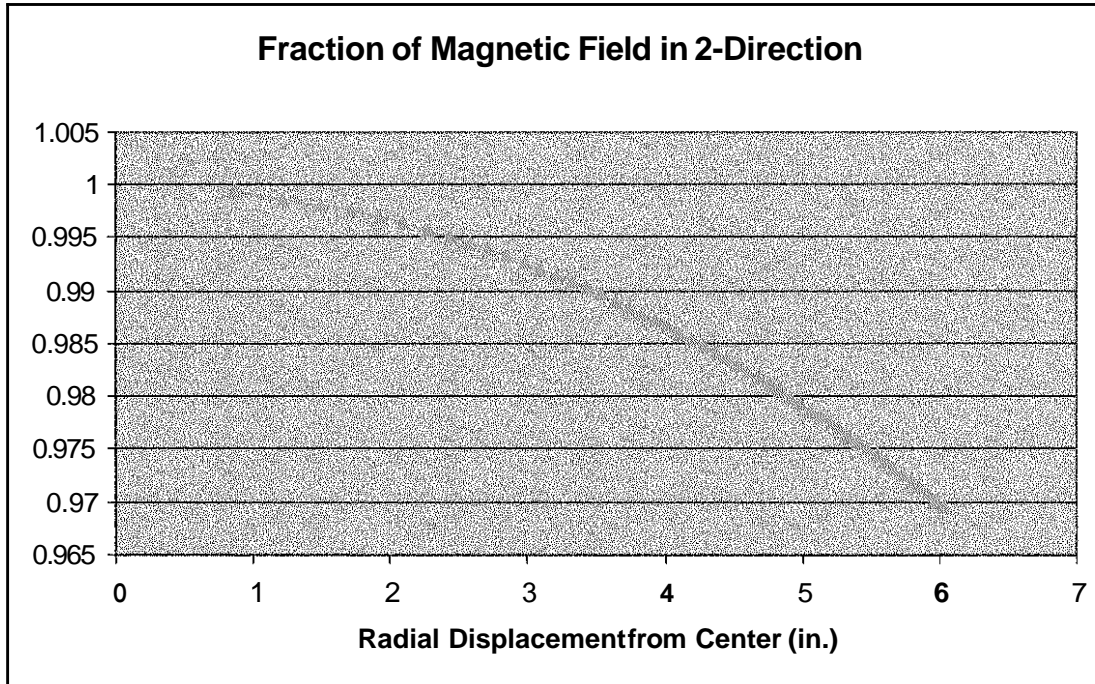

Figure 8: Point source field strength approximation in the vertical direction

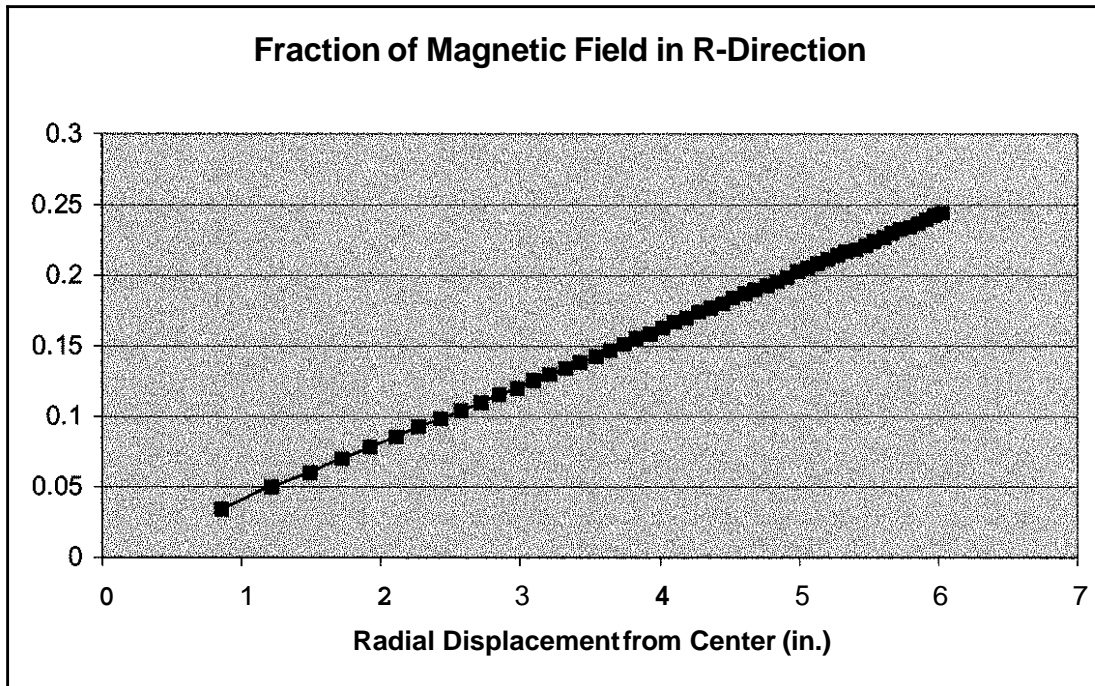

Figure 9: Point source field strength approximation within the median plane

Clearly, only experiment will enable us to select the most appropriate model.

VII. The RF Oscillator

The RF oscillator must be tuned very carefully to ensure beam acceleration. The protons exiting a DEE must see a negative charge in the DEE ahead of them or a positive charge in the DEE behind them in order to accelerate across the space between the DEEs. Thus the potential must be constantly switching between the DEEs.

The cyclotron circuit was originally tuned to a frequency of 13.56MHz due to the requirements of the commercial RF generator in use. Using the cyclotron frequency relationship, $f = qB / (2\pi m)$, we find that a magnetic field of 0.889 Tesla is required.

An HP8165 digital programmable RF signal source drives an ENI350L 100 watt solid-state amplifier. The output of the amplifier is passed through a Bird wattmeter and on to the RF cabinet, which houses the impedance matching transformer. This transformer matches the RF power of the 50R line into a high impedance load, the DEE. Since the DEE has such high impedance, a high voltage develops across it, alternating at 13.56MHz. In the case of this cyclotron, there is only one real DEE. The second DEE has been faked using the image of the real DEE on a grounded conductor. Thus, this image DEE appears to be of opposite charge compared to the actual DEE. So, the 50R RF source is coupled to the matching network, which is connected to the high impedance chamber. Another relationship we can use is $f = 1 / [2\pi(LC)^{1/2}]$, to determine the necessary inductance for the circuit, as the capacitance is fixed due to the physical geometry. The inductance must be chosen so that the resonant frequency of the circuit matches the frequency of the cyclotron. By twisting the inductor, we can change the inductance to match our inductance requirements. In this way, an alternating high voltage is produced on the DEEs in the chamber.

Increasing the DEE voltage increases the electric force on the proton between DEEs. Since the particles feel more force, they accelerate more across the gap, and reach the necessary energy more quickly. Thus, increasing the voltage effectively reduces the path length. Clearly, a short path length is desirable to prevent the proton from interacting with other particles inside the vacuum that might steer it off course.

VIII. The Q (quality) factor

A common measurement to make on an oscillator is the quality, or Q, of the circuit. Q can be determined in several ways including the following.

$$Q = \frac{f_r}{\Delta f} = \frac{\omega L}{R} = \frac{\Delta E_{stored}}{\Delta E_{lost}}$$

The resistance in this calculation refers to the total circuit resistance, which is made up almost solely of coil resistance. Thus, the circuit Q can be taken to be the Q of the coil. At resonance, the current will be equal to the applied voltage divided by the resistance. At frequencies far from resonance, the current is practically independent of resistance, and is very near what the current would be for no losses. Since Q and current are inversely proportional to resistance, the result of increasing the resistance is a flattening of the resonance curve by reducing the current at resonance. For higher resistances, the current increases less dramatically with the approach of resonant frequency, which gives a broader range of resonance. For lower resistances, however, the increase in current is more dramatic and the width of the resonant peak is much narrower, which increases the selectivity of the tuned circuit. Thus, high precision is necessary for a coil or circuit with a high Q value, so tolerance can be traded in for accuracy. The Q of this cyclotron was measured at **1600**, under no loading.